



ASTIR CS

FLIGHT MANUAL G102

The Manual belongs to ASTIR CS

Registration Number: _____ Serial Number: _____

Manufactured by: Burkhart Grob Flugzeugbau
86874 Tussenhausen - Mattsies
Flugplatz Mindelheim - Mattsies
Telephone: 08268-998-0
e-mail: productsupport@grob-aerospace.de
Germany

Owner:

Published: August 1975

This manual should always be kept on board the glider

List of effective pages

Chapter	Page	Date	Reference
Flight Manual	Cover Page	28.11.2005	
	2	28.11.2005	
	3	28.11.2005	
	4	28.11.2005	
	5	28.11.2005	
	6	28.11.2005	
	7	28.11.2005	
	8	28.11.2005	
	9	28.11.2005	
	10	28.11.2005	
	11	28.11.2005	
	12	28.11.2005	
	13	28.11.2005	
	14	28.11.2005	
	15	28.11.2005	
	16	28.11.2005	
	17	28.11.2005	
	18	28.11.2005	
	19	28.11.2005	
	20	28.11.2005	
	21	28.11.2005	
	22	28.11.2005	
	23	28.11.2005	

Contents

Contents	page
List of effective pages.....	2
Contents.....	3
Addenda.....	4
Flying Limitations.....	5
Record of weight alterations and weighing.....	7
Placards to be displayed in the cockpit.....	9
Notes on Flying the Glider.....	13
Emergency Procedures.....	16
Minimum equipment.....	18
Weight and center of gravity positions.....	18
Measurements.....	18
Weights and moments of the control surfaces.....	22
Assembly.....	22
Checks to be made after assembly.....	24
Pre-Launch checks.....	24

Addenda

Current number	Page	Reference	Date	Signature
Addenda for ASTIR CS				
9	all	Incorporation of all Service Bulletins, Changes and Editorial Revision	28.11.2005	

Flying Limitations

Airspeed Limits (I.A.S.)	km/h	mph	kts
Never exceed (V_{NE})	250	155	135
in rough air (V_B).....	250	155	135
Maneuvering (V_A)	170	105	92
On aero tow (V_T)	170	105	92
On winch tow (V_w)	120	74	64
Airbrakes	250	155	135
Gear extended	250	155	135

A.S.I. Colour Code

33 - 92 kts Green Border - 60-170 km/h
 92 - 135 kts Yellow Border - 170-250 km/h
 At 135 kts Red Strip - bei 250 km/h

Weights	lbs	kp
Empty Weight.....	circa 560	255
Maximum permitted weight without water-ballast	836	380
with water-ballast	990	450
Maximum permitted weight of non-supporting ports	528	240

Weak Link on Winch cable

Maximum Load 1100 500

Cloud Flying and simple Aerobatics

Permitted if water-ballast is not being carried: See pages 12 - 14

Classification Group

Standard Class (German N)

Centre of Gravity positions

Leveling means	with a 1000:40 Incidence Board set up horizontal on the top of the rear fuselage.
Datum Line (D, L.)	Front edge) of wing at root
Serial-No. 1002 – 1437:	
Maximum forward position of C. of G.	250 mm behind D. L. (9.84 in)
Maximum rearward position	425 mm behind D. L. (16.73 in)
Serial–No. 1438 – 1536:	
Maximum forward position of C. of G.	310 mm behind D. L. (12,20 in)
Maximum rearward position	480 mm behind D. L. (18,90 in)

Loading Limitations ASTIR CS

Empty weight of glider and maximum cockpit load, see page 7.

Minimum cockpit load: 154 lbs (70 kp)

The permissible all up weight must NEVER be exceeded.

Maximum all up weight

without water-ballast	836 lbs	(380 kp)
with water-ballast	990 lbs	(450 kp)

The weight of water-ballast is dependent on the cockpit weight (Pilot with parachute and luggage). See page 7.

Weight deficiencies should be corrected by securing or removing some ballast in the seat.

The C. of G. of the pilot with a parachute on lies 475 mm in front of the Datum Line.

Record of weight alterations and weighing

ASTIR CS Works Number:

Date of weight alteration: Weighing by	List of accessories (Date):	Empty Weight (lbs):	Empty Weight C. of G. position behind D.L. (mm)	Maximum Cockpit Weight (lbs)

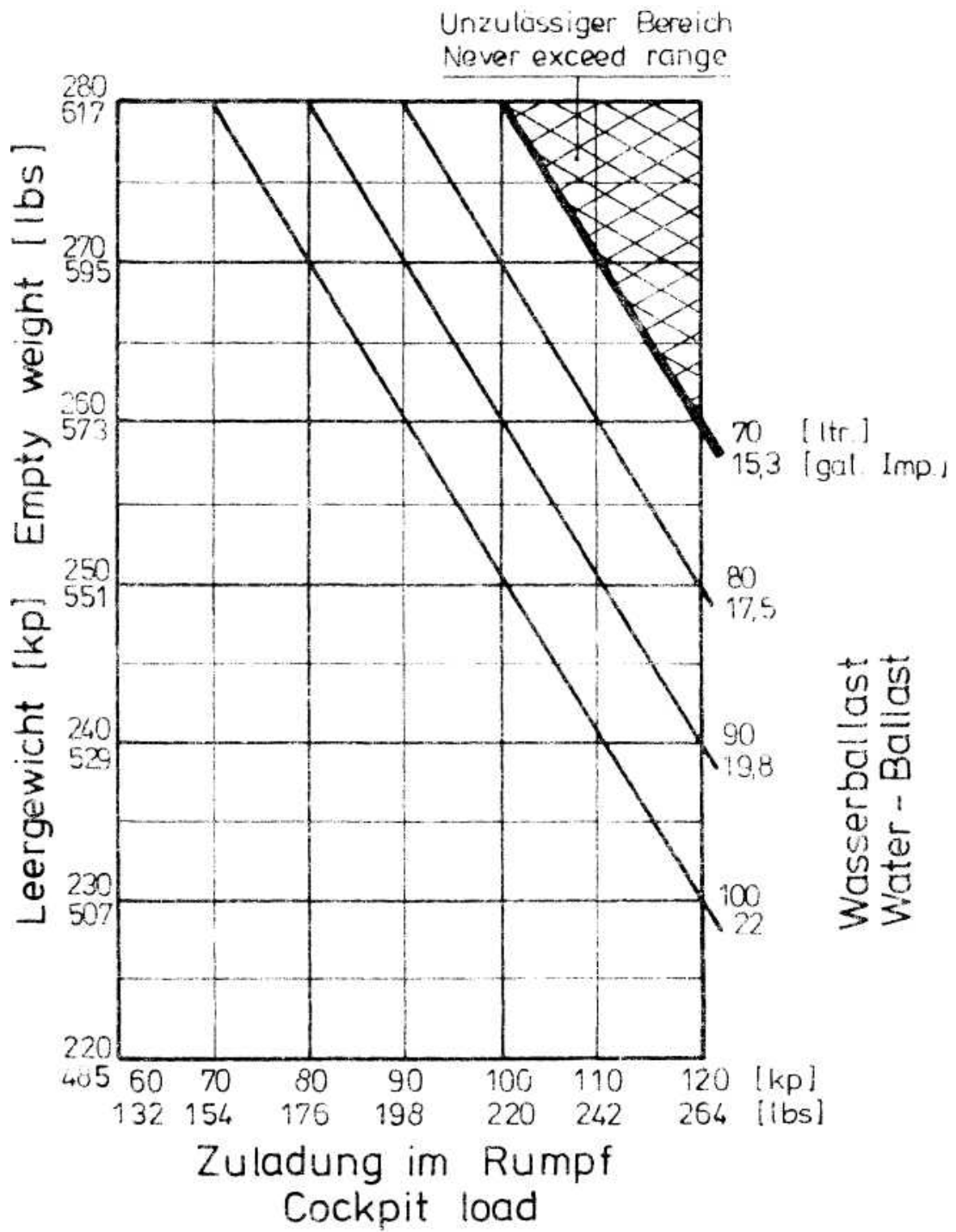

Placards to be displayed in the cockpit

Maximum weight		kp	lbs
without water ballast:		380	836
with water ballast:		450	990
Airspeed limits	km/h	m.p.h.	knots
Never exceed	250	155	135
in rough air	250	155	135
Manoeuvring	170	105	92
On aero tow	170	105	92
On winch tow	120	74	64
Airbrakes	250	155	135
Gear extended	250	155	135

Payload (pilot and parachute)
 The maximum weight must not be exceeded.
 Minimum payload: 70 kp, 154 lbs.
 Less weight must be compensated with
 ballast in the seat.

Placard to be displayed near undercarriage

Weak links for towing
 500 kp, 1100 lbs. max.
 Tire: 2,5 bar, 36 psi

Ballast Weight

Pilot Weight Incl. Parachute		Quantity (Total)
kg	lbs	
55	120	6
60	130	4
65	145	2
70 - 100	155 - 220	0

Cover of the container has to be closed tight.

**Ballast weight
red**

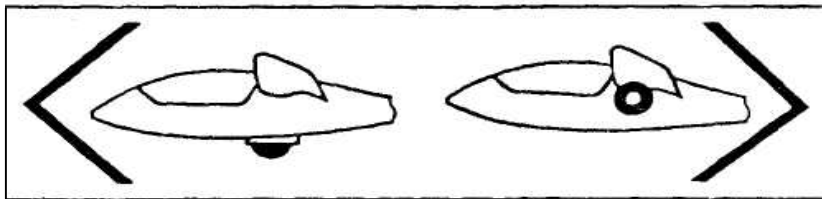

DOWN Under-carriage UP
Handle moves in Slot on right of cockpit

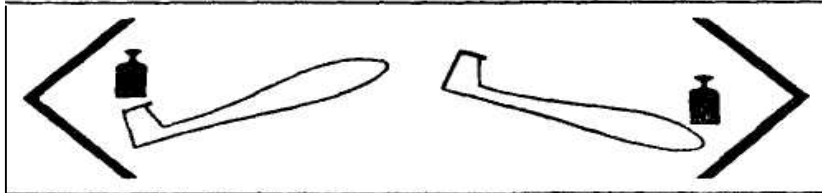

Trimmer
On left of cockpit. GREEN lever

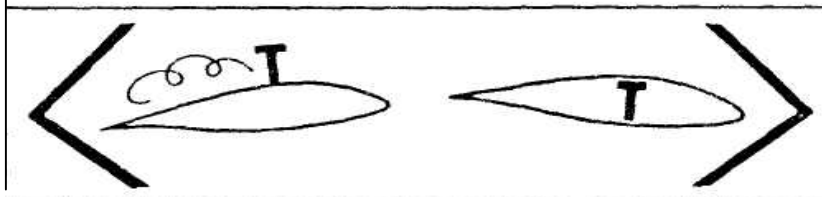

Air-brakes
On the left-hand Side of the cockpit BLUE handle

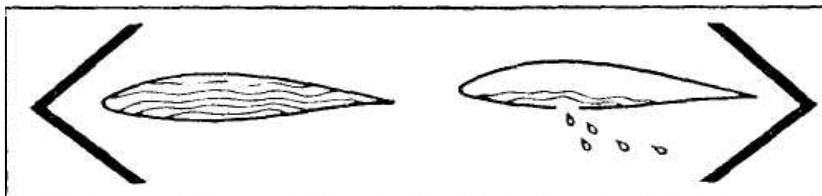

Water-ballast Jettison
On the right of the Cockpit. WHITE lever

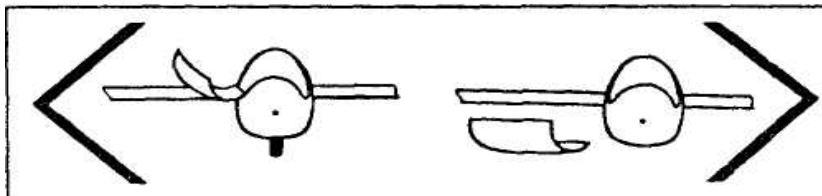

Canopy
Round RED knobs. Left of canopy-frame OPEN. Right of canopy-Frame JETTISON

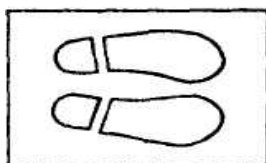

Pedal Adjustment
Small BLACK knob
On the top of the Instrument panel (right hand)

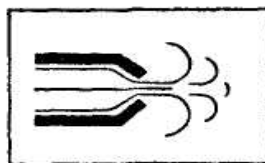

Air-vent
Small BLACK knob
On the top of the instrument panel. (left hand)

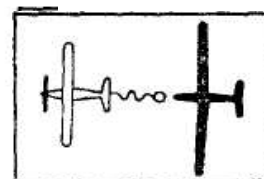

Cable Release
In front of the stick on the left. YELLOW knob

Graph of True v. Indicated Airspeed, showing the effect of Position Errors.

When the A.S.I. is connected to the following pressure sources:
 A.S.I. - Pitot head in tail fin static vents side of the fuselage before the wing root.

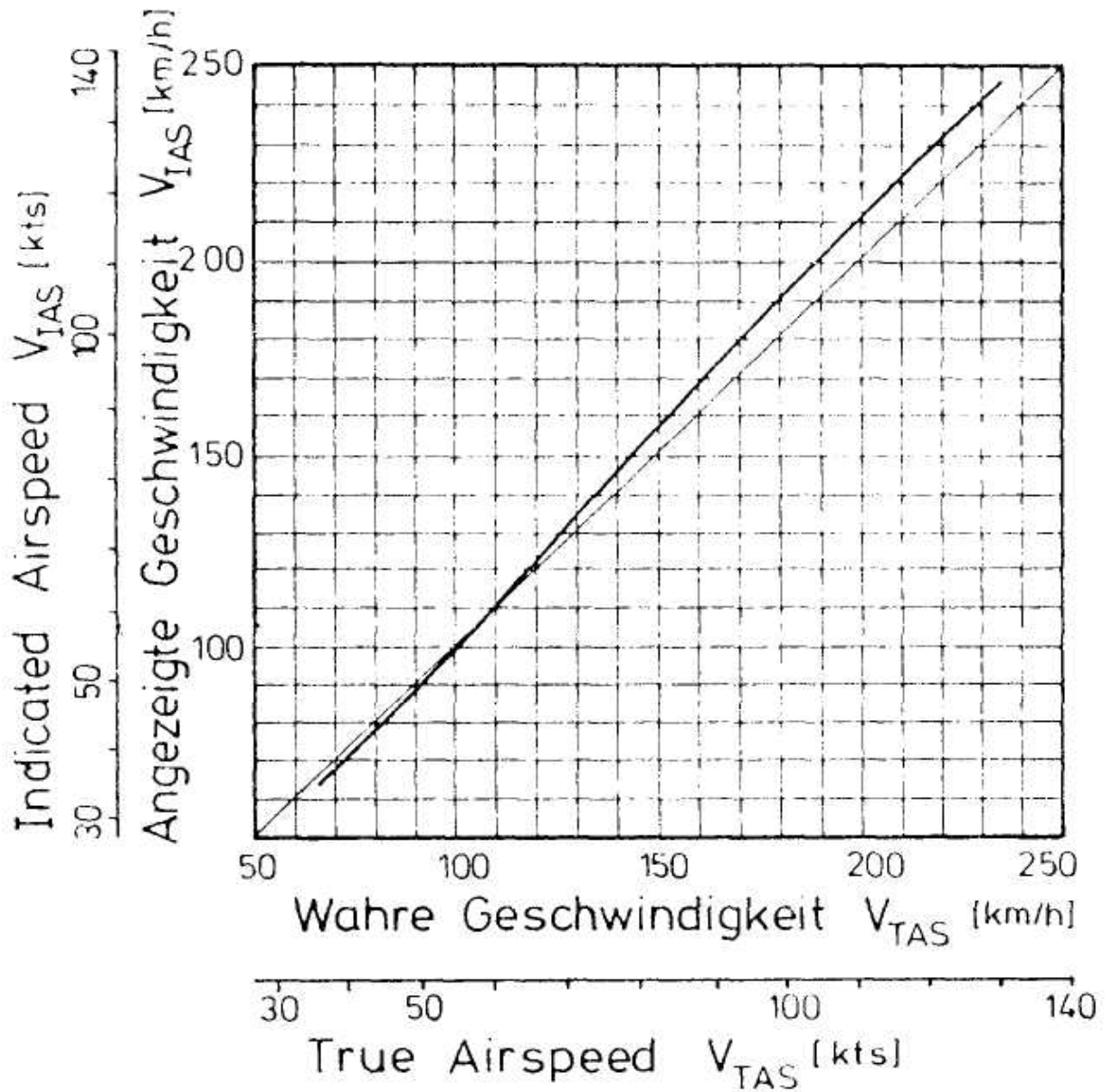

Notes on Flying the Glider

Winch/Auto-tow-Launch

Maximum permitted launch speed: 64 kts
The glider has a belly-hook in the undercarriage well in front of the wheel. A cable launch presents no difficulties with any C. of G. positions or weight configurations. The glider has no tendency to balloon and is very stable on the launch. Up to a height of 300ft the nose should be held down if the launch is fast.

Aero tow

Maximum permitted towing speed: 92 kts
The gliders C. of G. position allows the aero tow to be carried out using either the nose — or belly-hook. During the whole of the time on tow, the glider can be easily controlled with rudder and aileron, full movements of which can be used if necessary. Even in strong cross-winds the glider shows no tendency to wander around. At 32 kts the glider can be lifted off: with 37 — 40 kts indicated, the glider climbs on its own. The undercarriage can be retracted whilst still on tow. The yellow release knob is positioned on the left in front of the stick, and should be pulled fully back when releasing the tow-rope.

Weak Link in tow-cable

Maximum load 1100 lbs

Rudder-pedal Adjustment

To adjust the rudder pedals, push lightly forward on them with the heels and disconnect the locking device by pulling the handle on the instrument panel. The pedals move towards the pilot by themselves: to adjust them forward you have to push them against the pressure of the springs with your heels. The pedals will lock themselves in the position required when the handle is released.

Canopy

The single-piece perspex canopy has a clear-vision panel and ventilation port, and is fitted on hinges. The handle for opening it is located on the left-hand side of the canopy surround: that for jettisoning is on the right-hand fuselage side. To jettison the canopy, pull both handles back and push it up and away with the left hand.

Retractable Undercarriage

The undercarriage control lever is located on the right of the cockpit. When retracted or lowered, the wheel should be locked in place by pushing the control lever in towards the fuselage side.

Air-brakes

The lever for the air-brakes is situated on the left-hand side of the cockpit. Before beginning a launch, check that the air-brakes are closed and locked. One should avoid trying to land with full brake out, since the effectiveness of the brakes means that the glider is descending fast.

Wheel brake

The lever for the wheel brake is located on the stick.

Trim

The built-in trimmer can be progressively adjusted. The control lever for it is positioned on the left-hand side of the cockpit behind the airbrake lever. Trim range from 32 kts — 97 kts.

Flight with water-ballast

The glider has the same all up weight as a standard 2 seat glider, when loaded with water-ballast and a full cockpit load. The slow flight and stalling characteristics of the fully loaded glider are a little different from one flown without water-ballast. The stalling speed will be increased to 38 kts. Also larger control movements will be necessary.

The glider will spin cleanly but will recover immediately spin recovery action is taken.

The pilot is advised to have extra height when slow flying or approaching to land while carrying water-ballast.

Use of Water-ballast

The water-ballast tanks are situated in the front part of the wings, from the root outwards. Each wing can hold 50 litres. The tanks are filled through an opening in the top surface of the wing. This is covered by a plug, which can be removed by screwing in a bolt. The water is drained off through an opening in the underside of the fuselage behind the wheel-box. To open the valves of the tanks, the control lever on the right-hand side of the cockpit should be pulled backwards. It takes about 3 minutes for the tanks to empty themselves.

Air from the tanks escapes through the overflow pipe that runs down to a point on the underside of the wing near the root. When flying with water-ballast the connecting-tape that covers the gap between fuselage and wings, should be folded back on the underside in the region of the spar, so that any excess water which may appear runs out rather than down into the fuselage.

During long flights at an air temperature of 0 ° C (32 ° F) the water-ballast must be jettisoned because there is danger of collapse of the ballast tanks. When a field landing is to be made the water-ballast must be jettisoned.

The glider must not be parked over-night with water-ballast on board. If the glider has to be towed for a long way on the ground with water-ballast on board, the tanks should be emptied.

When de-rigging the water-ballast tanks will empty themselves through the wing root connecting pipes.

Stalling Characteristics

Warning of the stall occurs at a speed of 32-35 kts (depending on wing loading), when the top of the tail unit begins to shudder. If the stick is pulled back even further, the glider "mushes" but, remains controllable, it being possible to make turns up to an angle of bank of 20° without the wing dropping away. If the stick is released the glider returns immediately to the normal flying attitude. If the stick is pulled back quickly, the nose will drop away but any tendency for a wing to fall can be controlled by the rudder.

Aerobatics

Permitted maneuvers and speeds at which they should be initiated:

Loop	92 kts
Chandelle.....	92 kts
Steep turn.....	65 kts
Lazy eight	65 kts

Spins:

From the fully stalled position, put on full aileron and rudder (crossed). Keep the stick back. To stop the spin centralize or release one of the controls. Height lost per rotation is approximately 220 ft. The speed reached when leveling out is about 86 kts.

Maximal positive g loading + 5,3.

Manoeuvres that involve negative g loads are prohibited.

Unorthodox manoeuvres are likewise prohibited

Spinning

With the Center of Gravity between 415 mm and 480 mm behind the Datum Line, it is possible to put the glider into a spin from the stalled position. To do so the stick has to be pulled fully back, and the rudder and aileron controls be fully crossed. The nose will then drop in the direction in which rudder is being applied, and with a rearward C of G. position the glider will rotate in a slow, flat spin.

Recovery from the spin can be effected in any way you choose. With almost all C. of G. positions and wing loadings all that is required is for one of the controls to be released or returned to its normal position. The quickest recovery (without overstressing the glider) can be brought about by centralizing all of the controls. The height lost in returning to the normal flying position after a single-rotation spin, is about 220 ft,

If the glider fails to stop spinning immediately the controls have been centralized, then the standard method of spin recovery should be employed at once:

1. Full opposite rudder
2. Pause
3. Stick steadily forward
4. When spin stops, centralize controls and resume normal flight

Speed Flying

In speed flying it is quite possible to exceed the maximum permitted speed. At very high air speeds, care should be taken to use only small control movements so as not to overstress the glider:

Emergency Procedures

Escape Procedure

In the event of a bail out, the following procedure should be followed:

1. Pull both red knobs back on right and left of canopy surround and with left hand push canopy upwards and backwards.
2. Unbuckle seat harness.
3. EXIT over left or right side
4. Wait only 1 — 3 seconds before pulling the rip cord

Minimum equipment

1. 160kts. A.S.I
2. Altimeter
3. Vertical speed indicator
4. Four piece safety harness
5. Weighted seat cushion at least 2 3/4", thick, or parachute
6. Loading limitations chart
7. Flying limitations placard
8. Flight manual

Weight and center of gravity positions

If new Instruments are added and other changes in the weight of the glider are made, the empty weight C. of G. position should be checked. If the limits of the empty weight C. of G. positions and the Loading Limitations Chart are adhered to, then the C. of G. of the loaded glider will lie within the permitted range.

Serial-No. 1001- 1437

Serial-No. 1438 - 1536

Empty Weight (lbs)	C. of G. position (mm behind Datum Line)	Empty Weight (lbs)	C. of G. position (mm behind Datum Line)
506	606 — 693	539	696 — 753
517	598 — 693	550	688 — 747
528	591 — 637	561	681 — 742
539	534 — 682	572	673 — 737
550	577 — 677	583	652 — 732
561	557 — 672	594	631 — 728
572	537 — 667	605	611 — 723
583	518 — 662	616	591 — 719
594	499 — 658	527	573 — 715
605	481 — 654		

Measurements

Position of the glider whilst taking all measurements:

with a 1000:40 Incidence Board set up horizontal on the top of the rear fuselage.

ASTIR CS Serial No. 1438 – 1536

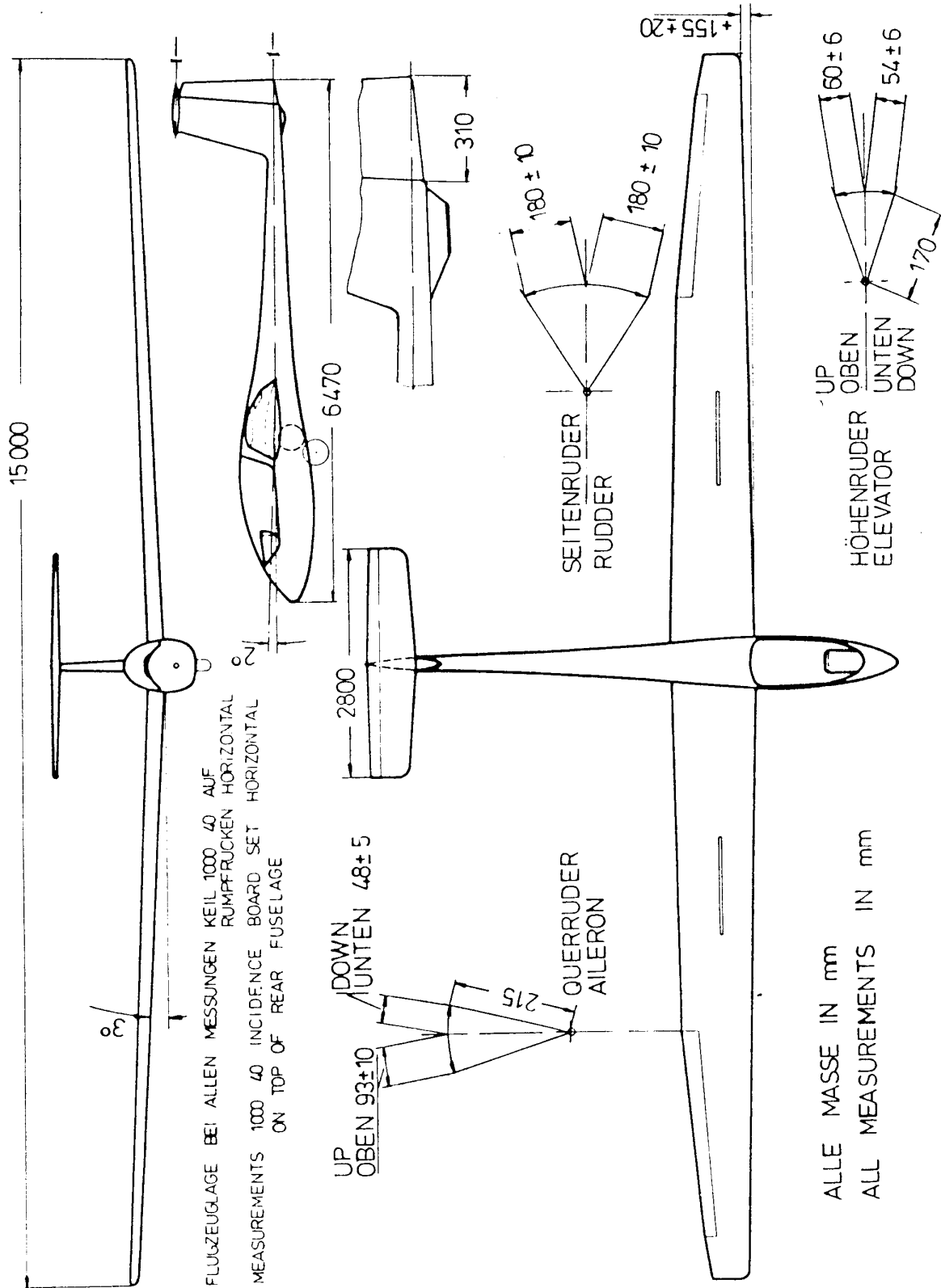

Performance	350 kp	450 kp
Best Glide Angle	37,3 - 95	38 – 105km/h
Minimum Sink (m/sec)	0,6 -75	0,7 – 85 km/h
Circling speed	80 – 85	90 – 95 km/h

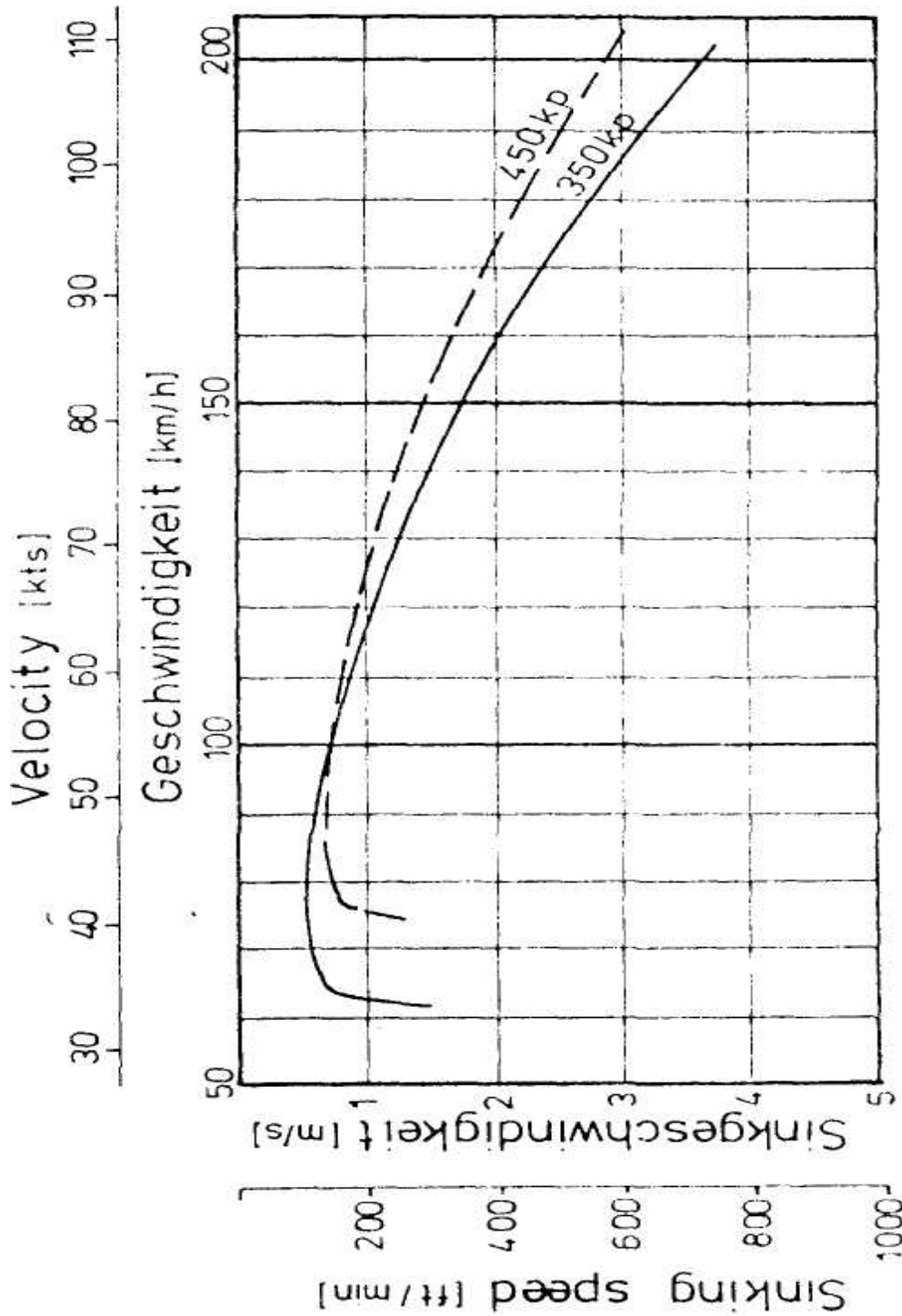

Geschwindigkeitsspolare ASTIR CS
Flight Polar

Weights

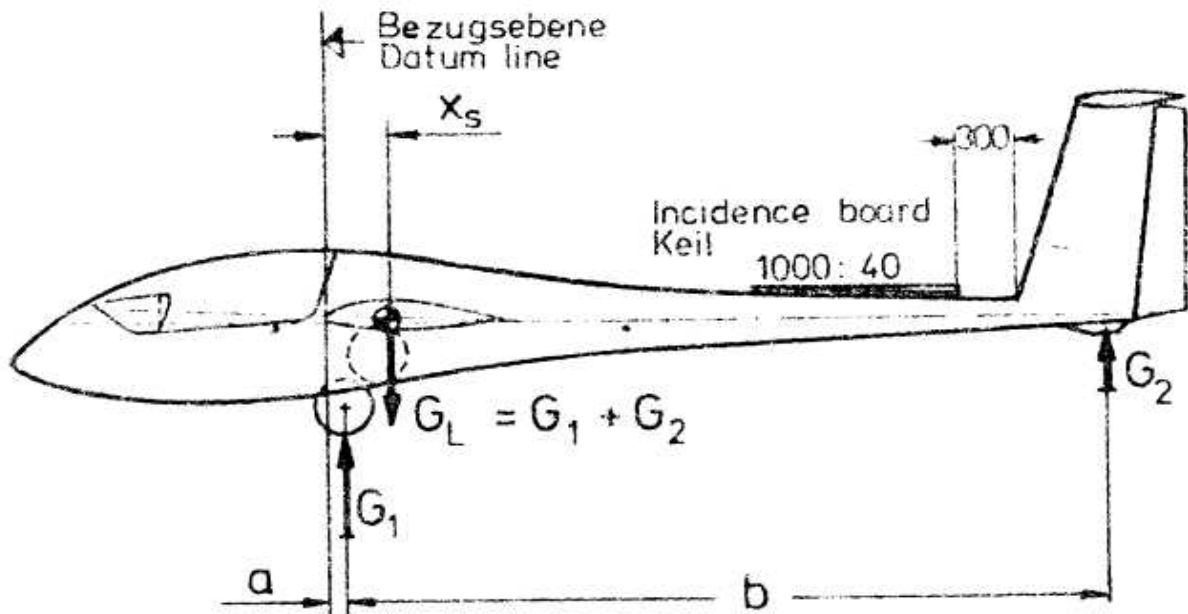

Datum Line: Front edge of the wing at the root.

Leveling means: With a 1000:40 Incidence Board set up horizontal on the top of the rear fuselage.

Weight on main-wheel	$G_1 =$	lbs
Weight on tail-skid	$G_2 =$	lbs
Empty Weight	$G_L = G_1 + G_2 =$	lbs
Displacement of main-wheel	$a =$	mm
Displacement of tail-skid	$b =$	mm

Empty Weight C. of G.

$$X = \frac{G_2 \times b}{G_L} + a = \text{_____} + \text{_____} = \text{_____ mm behind Datum Line}$$

$$\text{Maximum Load } G = 836 - G_L = \text{_____ lbs}$$

The measurements of determine the empty weight, the empty weight C. of G. and the loading limitations should always be taken with the glider empty of water ballast

Weights and moments of the control surfaces

After painting, partial painting or repairs the weights and moments and must not exceed. Procedure and limits see: Maintenance Manual ASTIR CS and SB 306-34, latest revision.

Assembly

It is possible to rig the glider with three people.

1. Wings:

Open the 4 main wing fittings in the fuselage. Unlock the air-brakes on the wings. Guide the right wing into the fuselage. The safety catches on the fuselage sockets will be released, and on gently moving the wing to and fro will be heard to snap into place. Next guide the left wing into the fuselage. Move the wing tips up and down so that the pin on each spar stub is located in the appropriate hole in the opposite wing root. Next the catches on the left-hand fuselage sockets should be released, and by moving the wing back-wards and forwards they too can be made to snap into place. To ensure that the wing-fuselage joint is safely secured, turn the socket catches towards the bayonets until they drop into place.

Checks

The red circles on the fuselage sides must be covered by the rotated sockets.

2. Aileron and air - brake-connections:

The short connecting rods in the fuselage are fitted with quick-action locks which must be coupled up to the knobs of the push-rods that move inside the wings.

To fasten the quick action locks, a special tool is provided which guarantees that the knobs are correctly located in the locks.

After rigging, the connecting rods should be examined to check that pins are properly inserted, and project some mm out of the locks.

After coupling the quick action locks, check that the ball can not be extracted, by twisting the lock back and forth. Do this gently with not more than 10 lbs pull. Check all control connecting rods and locks in a methodical order.

After rigging the following check must be carried out to check the connections are secure:

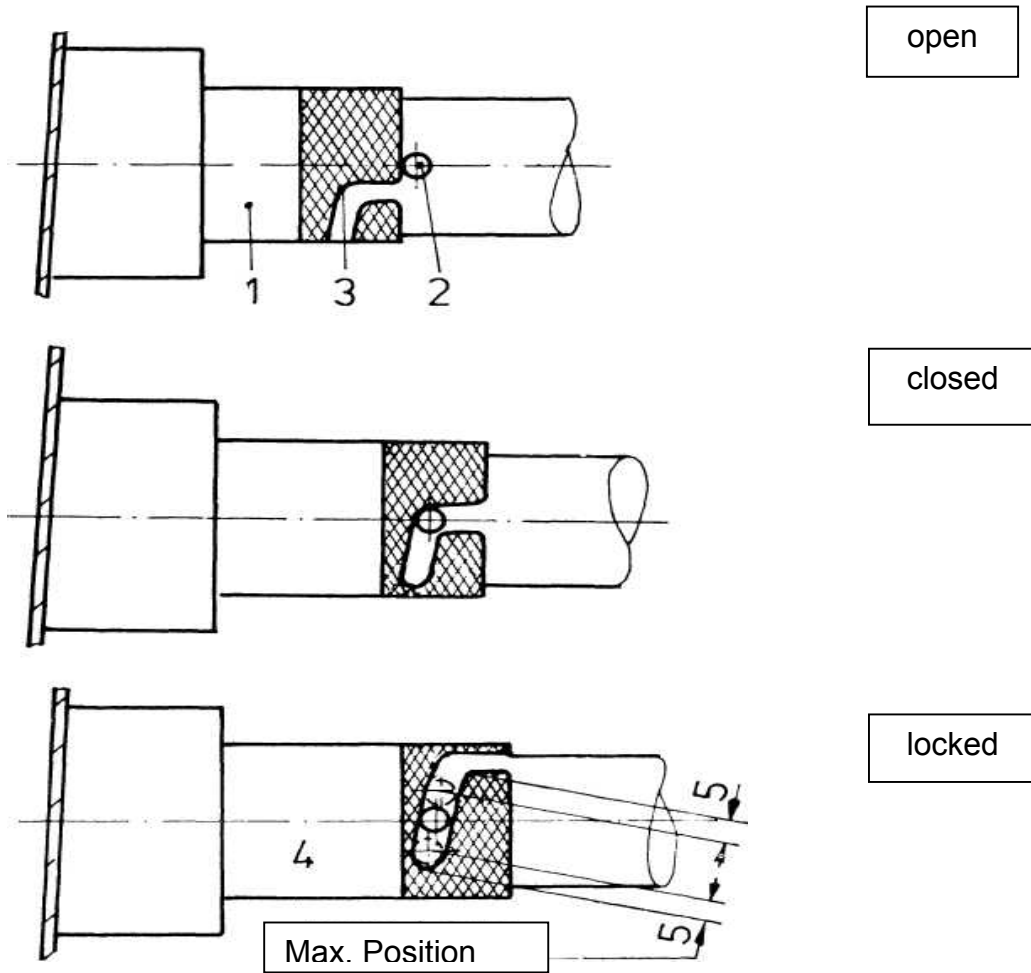

After connecting the quick lock couplings make a visual check that the collar is extended forward over the bearing far enough for the safety pin to engage.

3. Tail plane

The tail plane can be fixed in place by a single person. Stand in front of the fin. Rest the elevator on the rudder and point the tailplane upwards at an angle of about 45° with the fin. Next couple the elevator push-rod to the knob on the elevator by means of the quick-action lock. Now drop the tailplane down so that the two retaining pins on the fuselage disappear up into the cavity in the tailplane. One can now let go of the tailplane.

To continue with the rigging push the front of the tailplane down. This will activate the locking bolt and cause the metal pin that projects out of the front of the fin to move down its slot. When the front of the tailplane has reached its lowest position against the pressure of the locking mechanism, push the whole unit back with both and into the two fuselage bolts. The unit is then locked in place when the metal pin in the front of the fin springs upwards and covers the long narrow slot.

Checks to be made after assembly

- 1 Check that the 4 main wing fittings are locked.
- 2 Check that aileron and brake quick-action locks are properly located on the knobs.
- 3 Ensure that the tow hook is functioning correctly.
- 4 Test the operation of the wheel brake and the pressure of the air in the tire.
- 5 Check that the tailplane is securely seated and that the elevator push-rod is connected.
- 8 Rudder movement.

Pre-Launch checks

- 1 Do all the controls move freely?
- 2 Are the air-brakes locked?
- 3 Is the undercarriage control lever in the most forward position and is it pushed in flush with the fuselage-wall?
- 4 Is the trimmer set at neutral?
- 5 Is the canopy locked?
- 6 Are the parachute and seat straps drawn in tight and secured?
- 7 Is the altimeter set to ZERO or the height of the airfield?
- 8 Is the radio turned on and set to the frequency being used by the airfield control?

~~Inspection of the airbrake locking lever~~

~~At the daily check the right and left hand airbrake locking levers have to be checked through the inspection openings in the wing underside. The lever are made of aluminum casting and have a facilitating hole. The following instruction has to be carried out:~~

~~Inspection of the airbrake locking levers for cracks in one of the 3 legs. For a better inspection the Plexiglas pane can be removed for easier access. The use of a magnifying glass is recommended.~~

~~If cracks are found, the exchange of the locking levers left and right hand No. 102-4123/4124 of aluminum casting for such of aluminum sheet (see TM 306-26) is required. If the aluminum sheet's are installed, the daily check is not longer applicable.~~

This section is not applicable since the AD 85-19-06 (TM 306-26) was complied with by John Sinclair of JJ GLIDER REPAIR on 5/15/86 as noted in the SS Maintenance Log.



ASTIR CS

MAINTENANCE MANUAL G102

The Manual belongs to ASTIR CS

Registration Number: _____ Serial Number: _____

Manufactured by: Burkhart Grob Flugzeugbau
86874 Tussenhausen - Mattsies
Flugplatz Mindelheim - Mattsies
Telephone: 08268-998-0
e-mail: productsupport@grob-aerospace.de
Germany

Owner:

Published: August 1975

List of effective pages

Chapter	Page	Date	Reference
Maintenance Manual	Cover Page	28.11.2005	MSB 306-38/1
	2	28.11.2005	
	3	28.11.2005	
	4	28.11.2005	
	5	28.11.2005	
	6	28.11.2005	
	7	28.11.2005	
	8	28.11.2005	
	9	28.11.2005	
	10	28.11.2005	

Contents

Contents	page
List of effective pages.....	2
Contents	3
Addenda	4
Maintenance	5
Annual Inspection	7
Life limited parts.....	8
Weights and moments of the control surfaces	9
Inspection Procedures for Increase of Service Time.....	10

Addenda

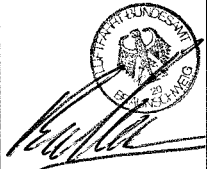
Current number	Page	Reference	Date	Signature
Addenda for ASTIR CS				
9	all	Incorporation of all Service Bulletins, Changes and Editorial Revision	28.11.2005	16. FEB. 2006 

Maintenance

The greatest care should be taken in maintaining the **fiber glass surface** of the glider. Luke warm water should be used to wash off dust, grease, dead flies and other dirty marks. More resistant dirt should be removed by using a mild cleaning agent. Only special silicon-free preparations should be used in maintaining the painted surfaces. Cracks should be carefully filled.

Although very resistant against moisture, the glider should be protected as much as possible against **rain and dampness**. Water that has penetrated, should be dealt with by storing the glider in a dry place, frequently turning over the dismantled parts.

The most effective way to clean the **canopy** is to use a special perspex cleaner, but if necessary, lukewarm water can be used. A soft, clean cloth or chamois-leather should be employed to wipe the canopy down. Never rub perspex with anything dry.

The safety harness should be regularly checked for mildew and general wear and tear. The metal parts of the harness should be frequently checked for rust.

Because of its position in the wheel cavity **the tow-hook** is susceptible to contamination from dirt. Therefore it must be inspected frequently for damage, also regularly clean and b grease. When the seat-well is removed the hook can easily be taken out. Remove the connecting wire from the lever and take out two retaining screws. For reconditioning the tow hook should be sent with the record card to the tow hook manufacturer, Tost.

The main wheel **tire pressure** should be kept at 2,5 atmospheres (36 psi).

A **tail wheel** can also be installed instead of the skid

The **wheel brake** is of the drum type. If required the point at which the brake begins to drag can be adjusted. The adjustment is carried out by moving the Bowden cable at the drum end.

When **the main wheel is removed** for the purpose of cleaning, greasing or changing the tire, the Bowden cable should be disconnected from the brake-lever. Screw the M 6 threaded special tool onto one side of the axle and take out the screws and the spindle. Remove the screws that hold the brake-lever in place. Take the wheel out by pulling it downwards. Clean all the parts and grease before re-assembly.

Before assembling the glider **the pins and sockets** at the joints between wings and fuselage, and tailplane and fuselage, should be cleaned and greased.

If **repairs** are carried out on the glider which are more extensive than normal maintenance work, the manufacturers should be contacted.

It is absolutely essential to ensure that if the glider is **re-painted** all surfaces which are directly exposed to the sun should be painted **WHITE**.

When any repairs are done or a fresh coat of paint added the position of the empty weight C. of G. must be re-checked.

Maintenance on Hotellier quick-locks must be conducted during each annual inspection or 500 hours whichever ever occurs first. They are installed at the control-connections of aileron and airbrakes at the wing-fuselage joint and at the elevator connection to the pushrod.

The diameter of the swivel has to be measured at different points by a micrometer with no differences in excess of 0,1 mm (0,004 in.) that means the swivel must still be spherical. If there are large differences the swivels and appropriate joints must be replaced.

Swivels and joints should be greased prior to each rigging.

The use of additional safety-pins guided through the holes of the wedge-type slides increases safety, (Safety-pins No. 500 307.71 from A. Wurth, Industrieservice, D – 90431 Nuernberg, Germany or from GROB- Werke)

Annual Inspection

During each annual inspection check front and rear attachment for noticeable play before de-rigging the horizontal stabilizer. Therefore move the stabilizer at the tips carefully to all directions.

- If play is noticed in the front attachment the spherical bolt must be replaced (see figure 1). Determine the ball diameter. When ordering advise the measured diameter "D" + 0.1 mm. Also advise gap width "S" as measured.
- Remove spherical bolt from elevator. Check bolt for cracks.
- Upon re-installation apply correct torque. (20 Nm, tolerance +4 / -2). (NOTE: See also MSB 306-38).

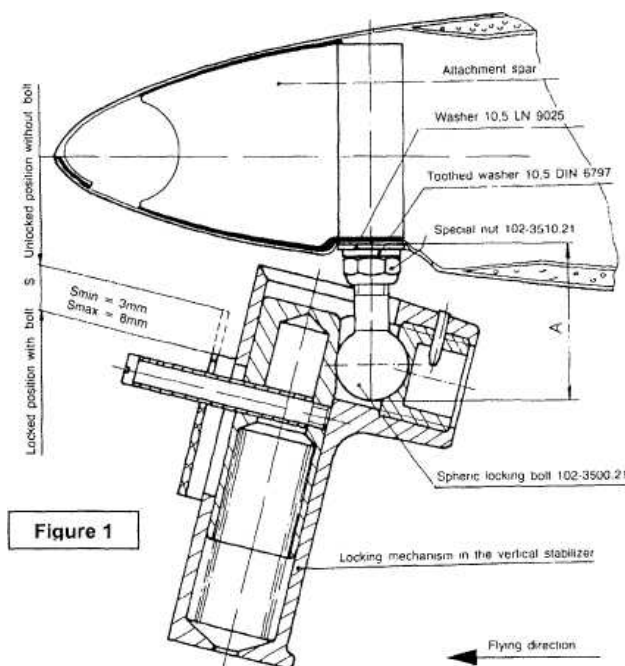

Figure 1

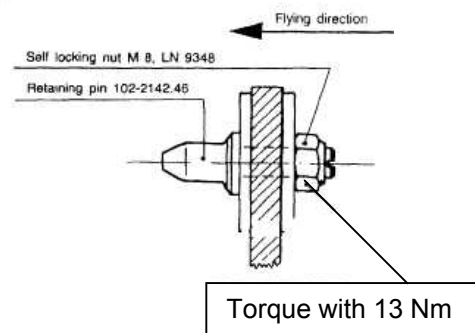

Figure 2

- if play is noticed in the rear attachment the retaining pins 102-2142.46 must be replaced as follows: (refer to figure 2):
 - remove horizontal stabilizer.
 - loosen nut M8, hold bolt using a screwdriver.
 - during removal of the bolts pay attention that the large washers remain on the aluminum plate.

- install new spherical bolts and pay attention that they are properly positioned in the large washers.
- tighten nut using a torque wrench with 13Nm.
- install horizontal stabilizer and connect control rods.

In case play is still noticeable after replacement of the bolts, the bearings in the stabilizer spar web must be replaced. This replacement must be done only by an approved aviation workshop.

Corresponding instructions may be ordered from GROB.

Life limited parts

Mandatory Service Bulletin MSB 306-38 introduced the annual inspection and – if required – the exchange of the spherical bolt 102-3500.21.

Mandatory Service Bulletin MSB 306-38/1 require all spherical bolts 102-3500.21 and collar bolts 102-2142.46 be exchanged not later than June 30th 2006, unless already exchanged within the scope of MSB 306-38. Additionally every 10 years / 1000 landings, whichever comes first, spherical bolt 102-3500.21 and collar bolts 102-2142.46 need to be replaced with new bolts.

The change is to be documented in the aircraft history record and life-limited-parts list.

Weights and moments of the control surfaces

The weights and the moments of the control surfaces must not exceed the following values:

ASTIR CS (Serial No. 1002 - 1536)

Elevator	10,00 – 15,00 kgcm	2,40 – 3,25 kg
Rudder.....	13,65 kgcm ± 10%	3,20 kg ± 10%
Aileron	16,00 kgcm ± 12%	4,10 kg ± 12%

The moments must be measured with the control surfaces removed. To determine the moment $M = P \times r$ the surface should be mounted at the hinge line with the minimum friction possible. The force P can be measured, for example, using a letter scale. If these values are exceeded the mass balance should be increased. Before carrying out repairs which for example involve charging the mass balance on a surface the manufacturer or his repair agent should be consulted.

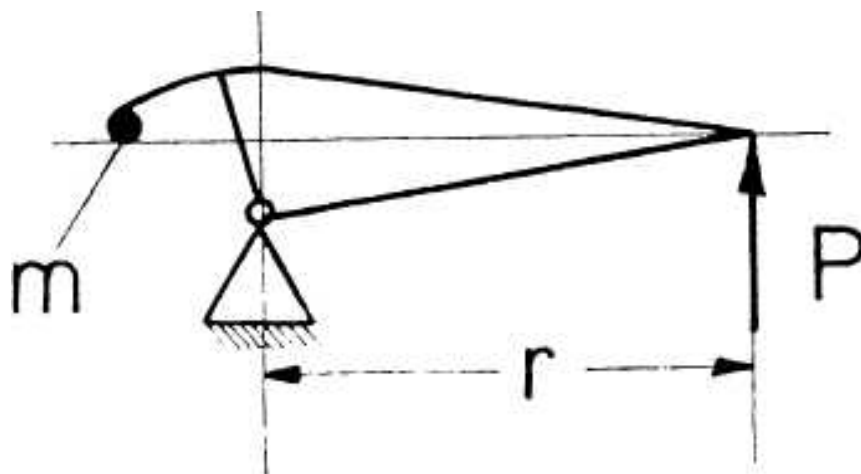

Inspection Procedures for Increase of Service Time

1. General

The results of fatigue tests of wing spar sections have demonstrated recently that the service time of GRP gliders and motor gliders may be extended to 6000 hours, if for each individual glider (in addition to the obligatory annual inspections) the airworthiness is demonstrated according to a special multi-step inspection program particularly with regard to the service life.

2. Time limits

When the glider has reached a service time of 3000 hours, an inspection must be done in accordance with the inspection program mentioned under point 3. If the results of this inspection are positive or if any defects found have been duly repaired, the service time of the glider is extended by another 3000 hours to a total of 6000 hours (first step).

The above inspection program must be repeated when the glider has reached a service time of 6000 hours. If the results of this inspection are positive or if any defects found have been duly repaired, the service time of the glider is extended to 7000 hours (second step).

When the glider has reached a service time of 7000 hours, the above inspection program again must be repeated. If the results of the inspection are still positive or if any defects found have been duly repaired, the service time may be extended to a total of 8000 hours (third step).

The gradual extension of service life will be performed by steps of 1000 flight hours up to maximum 12 000 flight hours at this time (4th – 7th stage).

Additionally at 9500, 10500, 11500 operating hours, inspection of the wing connection bolts and main spars spigots must be performed accordance to Service Bulletin TM 306-30, latest edition, action 7.

3. Inspection Program

In each case the latest issue of the inspection program which will be updated according to incoming inspection results, has to be ordered from the manufacturer.

4. Inspections

The inspection must only be done by the manufacturer or by a licensed repair station or inspector.

5. Inspection results

The results of the inspections have to be recorded in an inspection test report wherein comments are required for each inspection instruction. If the inspections are done outside the manufacturer's facilities, a copy of the records must be sent to the manufacturer for his evaluation and information

6. Annual Inspection

The annual inspection is not affected by this inspection program.



ASTIR CS

REPAIR INSTRUCTION G102

The Manual belongs to ASTIR CS

Registration Number: _____ Serial Number: _____

Manufactured by: Burkhart Grob Flugzeugbau
86874 Tussenhausen - Mattsies
Flugplatz Mindelheim - Mattsies
Telephone: 08268-998-0
e-mail: productsupport@grob-aerospace.de
Germany

Owner:

Published: August 1975

List of effective Pages

Chapter	Page	Date	Reference
Repair Instruction	Cover Page	28.11.2005	
	2	28.11.2005	
	3	28.11.2005	
	4	28.11.2005	
	5	28.11.2005	
	6	28.11.2005	
	7	28.11.2005	
	8	28.11.2005	
	9	28.11.2005	
	10	28.11.2005	
	11	28.11.2005	
	12	28.11.2005	

Contents

Contents	page
List of effective Pages	2
Contents	3
Foreword	3
Authorized materials and suppliers	4
Simplified texture plan of Astir CS	6
Repair of GRP material	7
Repair of GRP Foam-Sandwich	7
Repair of styrene-foam supported parts	9
Repair of GRP laminate parts.....	9
Paint-Work.....	9
Repair of Metal Fittings	11
Major Repairs	11
Construction details of additional equipment attachment fittings.....	12

Foreword

The glider ASTIR CS is constructed from glass fibre reinforced plastic (GRP). The fuselage and control surfaces consist of GRP laminate. The load bearing surfaces (wings) and the tail plane consist of GRP laminate with a foam supporting layer (GRP foam-sandwich). The tail-fin consists of GRP styrofoam sandwich.

Authorized materials and suppliers

Resin: Shell Epikote 162

Hardener: BASF Laromin C 260

Mixing ratio: 100 parts resin - 38 parts hardener, parts by weight

Glass Fibre Cloth: Supplier: Interglas Textils GmbH. Söflinger Str. 246, 7900 Ulm

Use	Cloth	Weight g/qm	Interglas-No.
Fuselage	Double Twill	161	92 110
	Double Twill	390	92 140
	Chain Reinforced	433	92 146
Wings	Double Twill	161	92 110
	Double Twill	276	92 125
	Chain Reinforced	433	92 146
Elevator and Rudder	Double Twill	276	92 125
Ailerons	Double Twill	276	92 125
	Double Twill	161	92 110

All glass-fibre cloth is Alcholine free. E Class with Volan-A-Finish or Finish I 550.

Glass fibre cloth and resin/hardener may be ordered from:
GROB-WERKE, Burkhard Grob e.K. Unternehmensbereich Luft- und Raumfahrt,
86874 Mattsies, Flugplatz Mindelheim-Mattsies, Germany.

Rovings:

EC 10-80-2400 K 43

Supplier:

Gevetex
4000 Düsseldorf
Postfach 1205**Foam Material:**PVC-Hartschaum
Conticell 60, 6 and 8 mm thick
Spec. Weight 60 kg/m²Continental AG
3000 Hannover**Styrofoam:**Thermopete
4 mm thick
Spec Weight 15 kg/m³Poron-Werke GmbH
6122 Erbach
Brunnenstrasse 5**Filling Material for Resin:**

Microballoons Brown

Lackfabrik Bader KG
7300 Esslingen
Schließfach 25Cotton Flock
Type FL 1 fSchwarzwälder Textil-Werke
7623 Schenkenzell
Postfach 12**Paint:**PE-Schwabbellack
White. No. 3-69120
PE-Hardener No. 07-20500
100 Schwabbellack Paint (Gel-Coat)
10 Hardener mix ratio by Weight.
Thinners No. 6-10170Lesonal-Werke
7000 Stuttgart 30
Postfach 30 07 09Red Paint
Nitro-Cellulose-Kombilack
Blood-Orange RAL 2002Lackfabrik Bader KG
7300 Esslingen
Schließfach 25

Manufacturer and supplier data may not represent the latest status.

Simplified texture plan of Astir CS

Reinforced regions for special loads and stress conducting are not shown.

1. Flügel

Außenlaminat

1 Lage 92110 diagonal

1 Lage 92125 diagonal

Kern

Conticell 60 8 mm

Innenlaminat

1 Lage 92125

Wing

Outer laminate

1 Layer 92110

1 Layer 92125

Core

Conticell 60 8 mm

Inner laminate

1 Layer 92125



2. Rumpf

Von außen nach innen

1 Lage 92110 längs

1 Lage 92146 längs

3 Lagen 92140 diagonal

Fuselage

From outside to inside

1 Layer 92110 lengthwise

1 Layer 92146 lengthwise

3 Layers 92140 diagonally



3. Ruder

Höhenruder

Seitenruder

Querruder

2 Lagen 92125 diagonal

Controls

Elevator

Rudder

Aileron

2 Layers 92125 diagonally



4. Höhenflosse

2 Lagen 92110 diagonal

Kern: Conticell 60, 6 mm

1 Lage 92110 diagonal

Fin

2 Layers 92110 diagonal

Core: Conticell 60, 6 mm

1 Layer 92110 diagonally



Repair of GRP material

If the glider is damaged, first examine the outer surface very carefully, frequently other structural parts are involved, fractures can run hidden under the outer surface. Carry out repairs with extreme care.

On gliders made of GRP, the outer surface is stressed (load bearing), failure of this element may lead to structural failure.

Maintain a precise resin-hardener mixing ratio i.e. +/- 0.5% using a clean mixing pot. The ratio of fibre glass cloth — to resin mix is approximately 1 to 1. Grind or splice the repair location only shortly before applying damp laminate, so that dirt cannot contaminate and prevent safe adhesion. As in plywood, the alignment of the fibre glass cloth (lengthwise or diagonally) is of extreme importance to the strength. The required amount of fibre cloth and direction in the damaged area may be taken from the simplified texture plan, so that the damaged area can be restored to the correct wall strength. If a small piece of the damaged laminate is broken off and burnt, the remaining glass-fibres can be counted and identified.

Splicing and grinding are time consuming. Grind away as much as necessary so that the added patches do not protrude from the contour. If it is necessary to shorten the repair time it may be done with a hot air blower to speed the resin curing time.

Warning. A temperature too high will produce large air bubbles in the cloth / resin. An improvised warming chamber may be built out of foil, through which hot air can be guided to avoid local overheating.

Caution must be exercised when repairing control surfaces, be careful not to increase the weight since this may cause flutter of the respective control surface.

Repair of GRP Foam-Sandwich

(GRP Hard Foam-Sandwich)

Damage may happen to the outer surface only (outside laminate) as well as the whole skin (outside and inside hard foam laminate).

a) Superficial damage

With a split or fracture, the laminate may detach from the supporting foam. Start by removing loose laminate until firm laminate is reached. To remove the foam laminate use a grinding disk, grinding block or sharp knife. With a grinding block or sharp knife only remove the cloth around the damage. Splice ratio per cloth covering approximately 20 mm ratio laminate thickness to splice: approximately 1:50.

After grinding out the splice, the repair must be thoroughly cleaned. Remove the dirt (also out of the foam pores) with air pressure. Wash the splice with carbon tetrachloride or acetone, in case it has been contaminated with dirt or grease.

Fill up the pores of the foam with resin and micro balloons until it is smooth. Then join the laminates with the correct cloth, aligning it in the right direction.

Repairs must be dirt and grease free, (Figure 1)

At room temperature the resin will cure in about ca. 8 hours.

The repair can now be ground smooth and be painted.

Warning: Grind only edge of the repaired area

b) Damage of the complete sandwich structure

In case the inner laminate is destroyed, remove outer laminate that has no adhesion to the foam, enlarge the hole until core is firmly joined to inner skin, then it is possible to repair the inner laminate. To repair the inner laminate properly, an additional rim of at least 20 mm must be maintained. (splice ratio approximately 1:50).

The outer laminate shall be repaired as described in section a). The inner laminate must be carefully ground and cleaned from foam residue. (Figure 2). With minor damage a piece of thin plywood support may be glued onto the inner skin with construction glue, the cloth patch of the inner laminate can then be positioned. The hole will then be filled in with resin and micro-balloons mixed with styrene-foam balls. After curing (app. 8 hours at room temperature) the outer surface can be ground smooth and the outer cloth may be placed in position.

The plywood support should remain in position as part of the repair. When the hole is of large or of oblong size the plywood support should be held in place with thin nails which can be removed later, by pushing them out from the top surface.

Warning: The plywood support must be properly fastened to avoid any wrinkles in the cloth. (Figure 3)

Particularly with large holes in the sandwich structure, pre-fabricated foam structures shall be considered for weight reasons instead of the micro-balloons-resin filler. Prepare a piece of hard foam to fit exactly into the existing hole. The pores on the inside shall be closed with resin and micro-balloons, position onto the inner cloth to cure. The structure remains flexible to some extent (if required, warm up with hot air blower). The pre-fabricated structure shall be glued into the hole with thickened resin (cotton flocks or micro-balloons). Micro-balloons are used to close and smooth the outside pores, the repair area is then ground and the outer cloth is placed into position.

Repair of styrene-foam supported parts

Repair shall be done in analogy to repair of GRP hard foam structure. Styrene foam has an impermeable surface, filling of surface pores is not necessary, the fibre cloth is held in position with pure or slightly thickened resin. With large damage let layers cure one at a time to avoid wrinkling.

Warning: Do not use strong heat to speed up curing time, styrene foam may develop blisters thus rendering the repair useless.

Repair of GRP laminate parts

Repair to GRP laminate is simple. Splice the area around the damaged section, position fibre cloth in layers (largest patch first), after 2-3 hours, when the resin has partially cured smoothen area with resin and micro balloons. Splice length per layer approximately 20mm. Ratio of laminate thickness / splice length approximately 1:50. In case the splice area is contaminated clean with Carbon Tetrachloride or Acetone. With large damage a underlying support (plywood) should be used. Wet laminate should not bridge a gap of more than 20 mm unsupported. The plywood support can be held in place with glue and nails (e. g. metal fitting in fuselage) which can be removed afterwards (Figure 4).

Paint-Work

As soon as the laminate of the repaired section has cured, it can be ground roughly with (80 grit) sandpaper. Uneven spots must be filled and smoothed with white polyester filler. Grind with fine dry-grinding paper (150 grit) until a moderately smooth outer surface is produced. Before painting, the repaired section must be cleaned from grinding dust, residue or other foreign bodies.

When applying Gel-Coat (Schwabbellack) + hardener use a moderately stiff paint brush, put on several thin layers, until the laminate can no longer be seen. The individual layers should be allowed to harden and then ground with (360 grit wet paper), additional layers should then be added and likewise ground.

The final finish should be carried out with 600 grit or 800 grit dry and wet grinding paper and then polished with a silicon-free car polish or with hard-wax, using a polishing machine.



Abb.1
Fig.1



Abb.2
Fig. 2

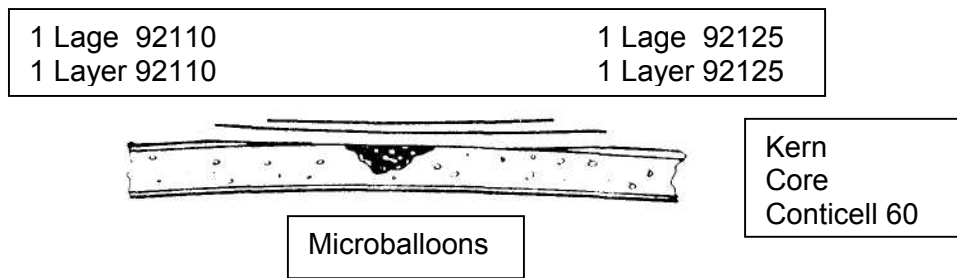

Abb. 3
Fig. 3

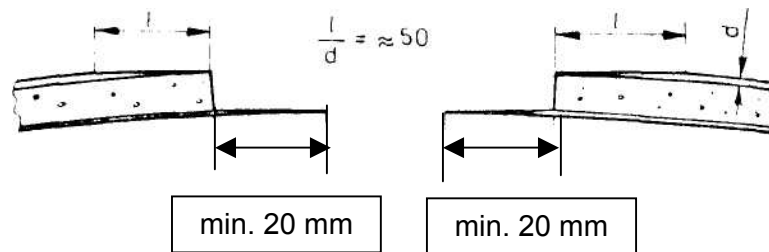

Abb. 4
Fig. 4

Repair of Metal Fittings

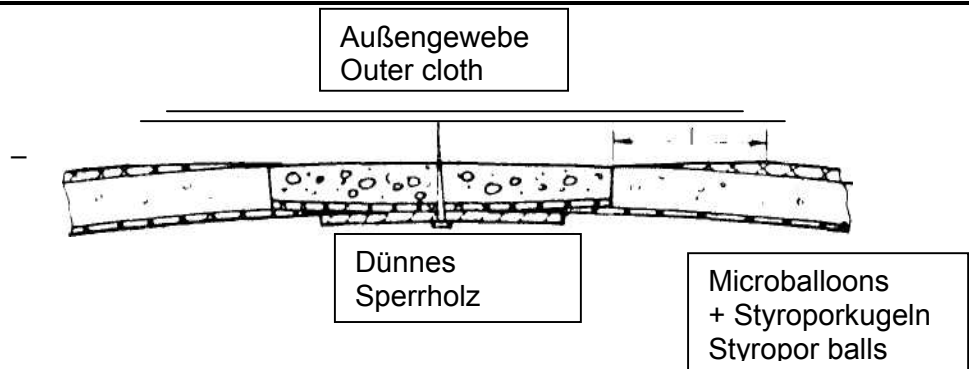
a) Steel Fittings

Repair of steel fittings made of should only be completed after consultation of the manufacturer. Welded steel fitting (push rods) made of 1.7734.4 BZW 1.0308.1 (St. 35.4). Welding only to be carried out with WIG Welding method and with welding material 1.7734 2 (for 1.7734.4) and 1.7324.0 (for 1.0308.0 or combination of 1.7734.4 and 10308.1)

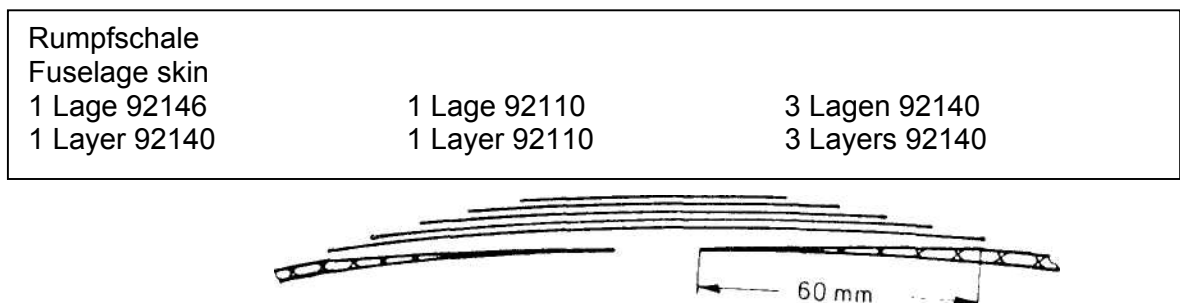
b) Aluminium Castings

Repair of aluminium castings 3.2374.6 cannot be carried out. Fractured or bent aluminium castings must be replaced by new ones.

Warning: Bent or chipped aluminium castings must not be bent back or straightened back to the original position.

c) Main wing / fuselage connecting rods

The main connecting rod between wing and fuselage (4x in the fuselage) contains 6 steel balls (\varnothing 6 mm) in each fitting. A sliding cover forces the steel balls into a groove in the moveable lateral axis, thus securing the wings.

In case one or more steel balls are missing, the connecting rod must be exchanged.

Major Repairs

Major repairs must only be carried out by the manufacturer or by a manufacturer approved repair organization. Major repairs include (amongst others)

- Broken off wings, fuselage, tail plane, control surfaces, spar stubs.
- Torn-out main fittings (fuselage tubes \varnothing 45 x 3)
- Fitting of the tail plane in fin. Securing bolts in the wing (\varnothing 18 mm), swivel bearing GE. 20, spar stub bolt \varnothing 20 mm).
- Destruction of main bulk (vertical frame).
- Damage to the GRP laminate (tear, splits, cracks) near the main fittings).

Construction details of additional equipment attachment fittings

The fittings for the oxygen bottles are built in as standard equipment on the right hand side of the luggage compartment. Supports and quick release buckles may be obtained from the manufacturer.

Other fitting points may be installed as shown. (Figure 5).

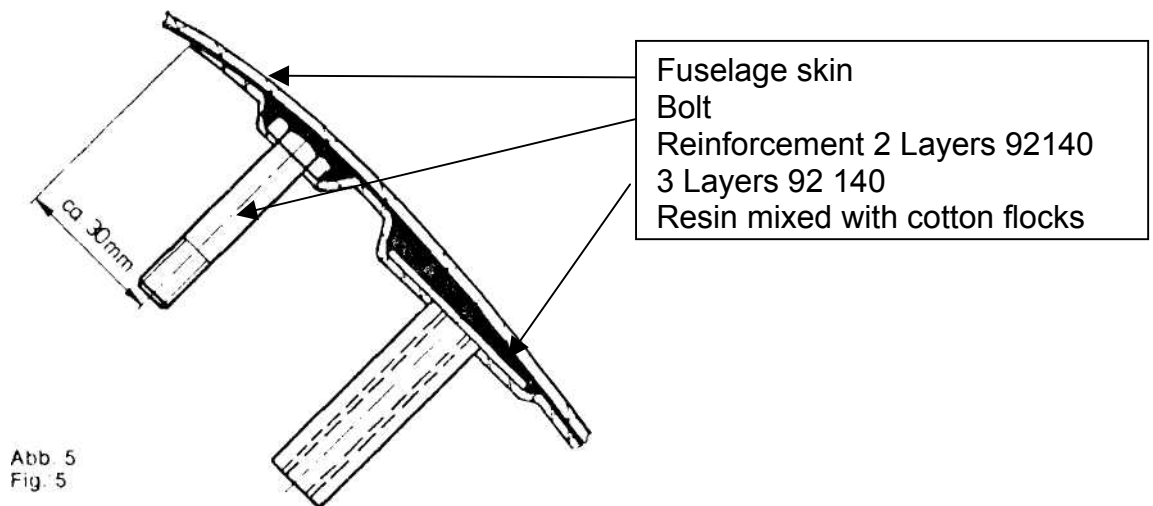

The fitting shall be made as shown in the drawing so as to take the weight of the additional equipment. Under loads of up to 10g no piece of equipment must come loose from its support. Following installation of additional equipment, a weight and balance report shall be compiled to ascertain that the C of G is within the permitted limits.